



Personalised Specification Sheet

KERAX 410.45 8X4 HEAVY E5

GVW 42

GCW 45,5

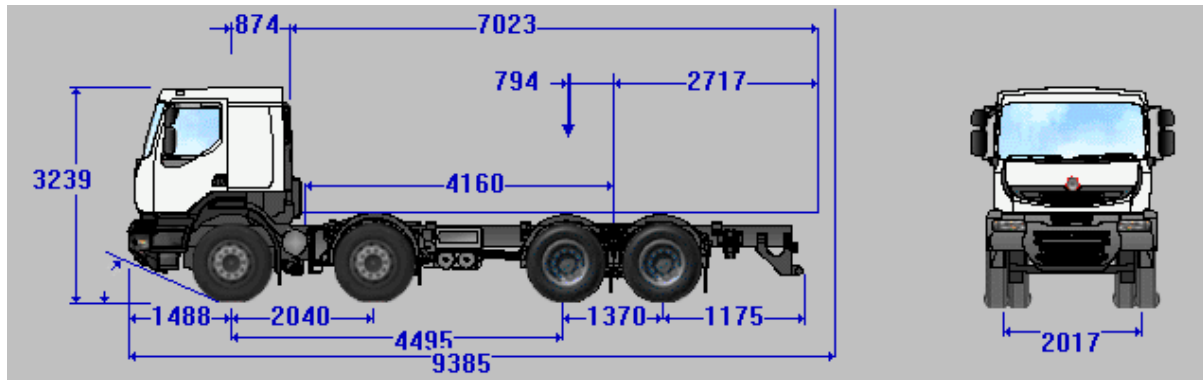

Engine speed at 90 km/h : 1464 rpm

Weights and dimensions

GVW kg.....	42000
Body Length Max (W) mm	7023
Body Length Min (W) mm	5681
Body / Payload Allowance kg.....	31246
Kerb Weight Total kg.....	10754
Kerb Weight Front kg	6815
Kerb Weight Rear kg.....	3939
Maximum Front Load kg	16000
Rear Axle Max Load kg.....	26800
Rear Axle 1 Max Load kg.....	13400
Rear Axle 2 Max Load kg.....	13400
Max Rear Overhang (X) mm	2717
Min Rear Overhang (X) mm	1375
Centre of Gravity of Min. Load (Y) mm	794
Centre of Gravity of Max. Load (Y) mm	1465
Max Overall Length (Z) mm	9385
Min Overall Length (Z) mm	8043
Body start position (B) mm.....	874
Wheelbase (F) mm.....	4495
Technical Wheelbase (F') mm	4160
Frame Rear Overhang (N) mm	1175
Chassis Length (A) mm.....	8528
Frame Height Unladen (H2) with standard tyres mm	1177
Frame Height Laden (H2) mm	1135
Unladen Cab Height mm.....	3239
Front Overhang (H) mm	1488
Front Axle Space mm.....	2040
Rear Axle Space mm	1370
Max Cab Width mm.....	2500
Track Width Front mm.....	2017
Track Width Rear mm	1872
Width at rear axle mm	2530
Ground Clearance Front mm	384
Ground Clearance Rear mm	340
Frame Width Front mm	1080
Frame Width Rear mm.....	850
Swept Turn Radius mm.....	10610



SPECIFICATION SHEET KERAX 410.45 8X4 R QUARRY E5

ENGINE DX11

Power: 302 kW (410 hp) at 1900 rpm.
Torque: 1900 Nm from 1100 to 1400 rpm.

Diesel, 6 cylinders in-line, turbocharged with INTERCOOLER with Wastegate (on 410 & 450hp). High pressure electronic injection (2000 bars) by 2nd generation pump injectors.

Monobloc cylinder head, 24 valves, overhead camshaft, rear distribution. Bore 123mm - stroke 152mm - capacity 10.8 litres.

Engine oil capacity : 36 litres.

Steel oil filter.

High capacity oil filter with replaceable cartridge.

Cooling system capacity : 33.5 litres (51 litres with hydraulic retarder).

Piloted starting.

Electronically controlled fan.

Rotation direction (as from G'box side) : anti-clockwise.

Starting device.

CEE EURO4 pollution control level (2001 / 72b1).

[PTO speed limiter.](#)

SCR post-treatment system with electronically controlled injection of AdBlue and preheating of piping.

Antifreeze protection: - 40 degrees.

Vehicle noise level set at 82 dB(A)

Euro 4 regulations, step 2. Reduction in engine power of 25% when vehicle emissions are above the legislative levels.

ENGINE EQUIPMENT

Exhaust brake

Fast idling control for PTO (Muddy site).

Electronic idling control.

[Engine rear PTO:Output: 100 mm](#)

[flange.Drive: full-time.Max. torque: 800 NmRatio: 1.08](#)

[Rotation: reverse of engine](#)

CLUTCH

CLUTCH 430 GD 900 (430 MFZ with Optidriver).

Cerametallic single plate. Air assisted hydraulic actuation.

Automatic adjustment.

GEARBOX

ZF 16 S 2220 TO16 synchronised forward gears and 2 reverse gears (13.80-0.84). Aluminium casing.

Pneumatic range splitter with preselection switch on the lever. Super H grid control. SERVOSHIFT assisted gear changing. Cable-operated control. Economic driving assistance with DMS (Driving Monitoring System).

RETARDER

Coupling of retarder and service brake.

Air operated engine exhaust brake.

POWER TAKE-OFF

Gearbox mounted PTO: S81 C.

Splined output for flanged pump.

Rotation: opposite to engine..

Torque: 1000 Nm

Ratios:

0.92 / 1.09 (16S1820TO - 16S2220TO)

Transfer case

REAR AXLE

Tandem P 3395Capacity 26 tonnes, double reduction by bevel gear and hub reduction units (2.26).

[Rear axle hypoid ratio 21 x 37 \(ratio 1.76\).](#)

Differential lock, between wheels and inter axle, engagement possible at low speed (managed by EBS)

STEERING

Hydraulic power assistance.

Integral hydraulic power assisted steering (2 independant circuits and 2 pumps).

FRONT AXLE

Front axle plating: 8000kg.

WHEEL AND TYRES

G.13 R 22.5 MSS/MSD.

Disc wheels.

Steel disc wheels.

Spare wheel with jack, delivered loose.

BRAKING SYSTEM

Main brake :

Electropneumatic braking system with two independent circuits, managed by EBS (Electronic Braking System).Drum brakes.

Electronic APM (Air Product Management):cartridge air dryer, optimised by preventive maintenance.compressor disabled during engine starts.

Compressor:

Twin-cylinder 636 cm3 piloted by APM.Declutching.Max. output: 660 litres/min at 2000 rpm (compressor).Ratio: 1.31

EBS :

Anti-lock braking system (ABS).Anti-slip regulator (ASR).Drag torque control (torque control during downshifting).Brake pad wear balancing (wear state and projected service life).Road rig braking harmonization.Emergency braking assistance.Braking performance alert.Management of diff. lock engagement at a speed of < 10 km/h on 4x2 vehicles

Anti-slip braking system (ASR).Hill Start Assist.Brake pad wear balancing.

Drum:

Diameter: 410 mm.Front width: 175 mm.Rear width: 200 mm.Brake lever 170 mm.Total linings area: 19 311 mm2.

Parking brake :

Air operated springs brake actuators on drive axle.

Alert parking brake.

Hand brake valve to EEC standards.

Emergency brake :

Provided by the independance of the two separate circuits.

Brake adjustment :

Automatic adjustment.

CAB

EXTERIOR :

All steel Cab, iron-zinc coated and cataphoretic paint treatment.

Glacier White.

2-door Global cab (2m).

Front panel with honeycomb radiator grille.

Anti-spray deflectors.

Four point mechanical cab suspension.

Hydraulic cab tilt mechanism.

2 heated, remote control, rear view mirrors.

Wide angle rear view mirror.

Kerb view mirror.

Front view mirror.

Tinted and laminated windscreen and windows.

Air intake ducting on left side of roof.

Access to driving position by 3 lit steps.

Flexible 1st step made from composite material.

Anti-slip windscreen access step.

Rear cab window.

Sun visor.

INTERIOR :

Normal roof equipped with storage ledge. 2 extra ISO modules. 2 storage compartments (50 l).

Storage box with net cover

Manually operated roof hatch.

Cab soundproofing.

Grab handles.

[COMFORT drivers seat: heated, lumber support, air suspended with seatbelt and headrest, wide rearward adjustment for increased leg room during rest periods.](#)

Adjustable passenger seat with safety belt.

Head rest.

Storage compartments in both doors.

Removable storage bin with a volume of 21 l behind the passenger's seat.

Cab lighting timer function.

Lower storage compartment

Boot socket on gear lever console.

Coat-hanger rod

2 electrically operated window raisers.



Numerical tachograph.

Manual integrated air conditioning for dusty air.

1 CD stereo radio set with fingertip control on steering column.

Engine hourmeter.

Handbook and Service pack in English.

INSTRUMENT PANEL :

Digital display with: - speedometer, radio information display, clock, outside temperature display.- driving information display.- driver warning messages and various menus.Analogue display:- central rev counter with economic operating zone, fuel, air pressure, engine water temperature gauges.- double flashing lights markings (tractor and trailer).- function and alert warning lights.- anti-reflecting glass.- information display menu control by radio fingertip controls.

Information display lighting intensity and sound level adjustment.Lights not switched on alert.

Drinking cup location or removable ashtray.

12V socket in cab.

Electrical headlamp levelling control.

Starting inhibitor controlled by infra-red key.

Remote control central locking

Cruise control.

Cigar-lighter

Instrument panel bleed control.

DIAG socket.

Access hatch to fuses and bodybuilder module box (BBM).

STEERING-MOUNTED EQUIPMENT:

Steering column lock.

Radio and information display pull-down menu (if thus equipped) steering column fingertip controls.

Retarder or engine brake control (if equipped).

Two speed windscreen wipers with incorporated washers and intermittent wipe.

Headlight control.

Adjustable steering column.

ELECTRICAL EQUIPMENT

Battery capacity: 225 Ah

24V voltage supplied by two batteries.Master switch and fuse box in battery tray.

Lighting to EEC standards.

Rear signalling lighting.

CHASSIS

Chassis width:Front: 1080Rear:

850Sidemembers module: 300 x 90 x 8.Sidemember lining: 5 mm.Necking of chassis under cab.

Overhang for concrete mixer, pre-drilled for bodybuilder.

3-piece steel shield integrating retractable windscreen access step, front grille, radiator protection shoe and towing yoke.

Detachable front towing yoke (25 tonnes) with unlocking by 1/4 turn lock.

Chassis rear cross-member.

Yoke towing

Rear under-run bar.

Wings on 2nd axle.

Tail lamps mounted on dedicated bracket.

Two wheel chocks with bracket.

SUSPENSION

Front :

Maintenance-free front parabolic, reinforced, 2-leaf springs (8 tonnes). Front anti-roll bar.

Rear :

Semi-elliptic leaf springs.

For very uneven road use : 32T capacity

8x4 Rigid : 11 leaf elliptic

For dirt track use : capacity is

increased to 38T in 4 leaf parabolic version

Rear anti-roll bar.

Telescopic shock absorbers on middle and rear drive axles.

FUEL TANK

Main steel tank: 330 litres capacity. (293 kg of diesel)

D- shaped 710.

Locking fuel filler cap.

Fuel preheater.

Adblue tank 36 litres plastic

STANDARD EQUIPMENT

Electronic speed limiter (90 km/h).

Vertical exhaust top discharge.

Cyclonic heavy duty air filtration system.

Tool kit.

Air valve on chassis.

Warning triangle.

Reversing warning buzzer, including night switch.

CAB

Headlamp protection grille.

BODYWORK

Provision for side marker lights.

Bodybuilder electronic box interface.

Power supply terminal plate 24V / 200A in battery tray.Round 7-pin socket provision under battery tray:- After master switch power supply 24V / 15A + earth (cab shared).- After ignition power supply 24V / 15A + earth.- Side/parking lights.- Alarm connection.

Air supply connection for bodybuilder

Body mounting brackets and body fixing plates for rigid attachment.

Standard fastening kit delivered for body mounting and attachment.

Note: No representation given.

Specifications subject to discontinuance, change and improvement. Dimensions, characteristics and data are for guidance only. We recommend that vehicles be measured and weighed before any body-building work occurs.no contract or binding undertaking is engaged by this document



IMER LT 9.7H mixer

Data sheet

Nominal capacity	9,7 m ³
Geometrical volume	16,100 m ³
Capacity in water	10.026 l.
Drum speed	0 to 14 rev/min, at 1.500 rpm of the truck engine
Drum angle	10°

Drum walls made of **30MnB5 anti-wear resistant steel** - HB 200/220 Nmm² (4mm thickness)
Mixing blades made of **30MnB5 anti-wear resistant steel** - HB 200/220 Nmm² (4mm thickness)

Motion

By P.T.O. on truck engine (excluded from our supply).

Controls

By cable with control box.

Hydrostatic transmission

Eaton 64 variable displacement hydraulic pump with 25cm³/rev feeding pump. Eaton 54 fixed displacement hydraulic motor.

LT 2.7 double stage planetary gearbox, max. output torque: 75.000 Nm.

Oil cooler with built in oil tank, complete with cartridge filter with indicator and electric fan with thermostat.

Water system

650 liter Steel water tank with level indicator.

LT130 water pump (450 l/min at 4 BAR) driven by P.T.O. on gearbox.

0-500 lt. Water meter.

Standard features

180° swivelling discharging chute with support and mechanical jack for lifting.

2 Polystone lightweight extension chutes with holders.

Anti-wear resistant plate on discharging hopper.

Inspection manhole.

Inspection ladder.

Wash off hose on ladder pedestal.

Drum lock (for safety maintenance operations).

Steel surfaces shotblasted in SA 2,5 grade.

Double primed in antirust painting.

The supply includes:

Anti wear plate on feeding hopper and on discharge chute

Mounting on 8x4 KERAX chassis already provided with PTO on engine flywheel and rear bumper.

Rear steel mudguards painted in black colour

Final painting in 1 colour

Side aluminium cyclist guards

Side remark lights

Reflecting stickers in accordance with U.E. norms